



Sauter GmbH

Ziegelei 1
D-72336 Balingen
E-Mail: info@kern-sohn.com

Tel: +49-[0]7433-9933-0
Fax: +49-[0]7433-9933-149
Internet: www.sauter.eu

Instruction Manual Digital Force Gauge

SAUTER FC

Version 1.1
07/2017
GB

Importør:
Impex Produkter AS
Gamle Drammensvei 107
1363 Høvik
www.impex.no
info@impex.no
Tel.: 22 32 77 20



PROFESSIONAL MEASURING

FC-BA-e-1711



SAUTER FC

Version 1.1 07/2017

Instruction Manual Digital Force gauge

Summarize:

1	General Specifications	4
1.1	Overview.....	4
1.2	LCD Screen	4
1.3	Key Functions.....	5
1.4	Specifications	5
2	Operation	5
2.1	Preparation.....	5
2.2	Testing	6
2.3	Save the measured value	7
2.4	Browse and print data.....	7
3	Setup	7
3.1	Setup menu	7
3.2	Measurement	8
3.3	Memory	8
3.3.1	Browse.....	8
3.3.2	Print	9
3.3.3	Delete All	10
3.4	System	10
3.4.1	Display	10
3.4.2	Auto Power.	11
3.4.3	Backlight.	11
3.4.4	Key Sound	11
3.4.5	Date/time	11
3.4.6	Calibration	12
3.4.7	Default	12
3.5	Language.....	12
3.6	Info	12
4	Communication Port	12
4.1	USB/Recharge.....	12
4.2	Multifunction port	13
4.2.1	RS-232	13
4.2.2	Setpoint Output.....	13
5	Maintenance and Calibration	14
5.1	Maintenance	14
5.2	Charging	14
5.3	Calibration	14
5.4	Troubleshooting	15

NOTICE

Please carefully read this first

1. During the test, please wear protective masks and gloves, because splashes could injure your body.
2. **DO NOT** exceed the capacity of the gauge. At 110% of the capacity, the display flashes and the alarm sounds; please remove the load immediately.

If 150% of the rated capacity is exceeded, the load cell may be damaged forever.
3. When mounting measurement adapters, tighten them by hand, **DO NOT** use tools.
4. FC series force gauge can only measure and bear axial forces, radial forces are too large and would damage the instrument.
5. Do not disassemble the gauge by yourself, it may damage the instrument.
6. Please use and store it in a suitable environment, as not to reduce the service life or cause failure.
7. To avoid injury, do not point the light beam of the instrument or let it reflect into the eyes of people or animals.
8. Do not leave the device close to water or any other liquid, to avoid damage.
9. If the instrument isn't used for an extended period of time, batteries have to be removed. They have to be recharged every 2-3 months to prevent a potential battery leakage and causing any product damage.

1 General Specifications

1.1 Overview

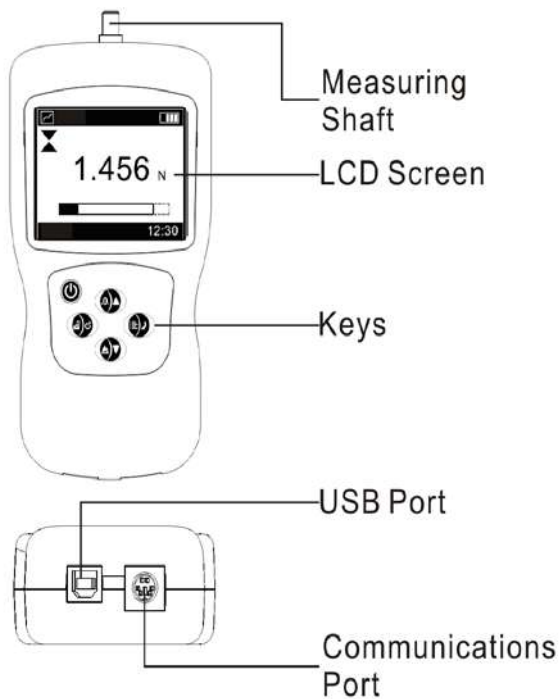

Fig 1-1

1.2 LCD Screen

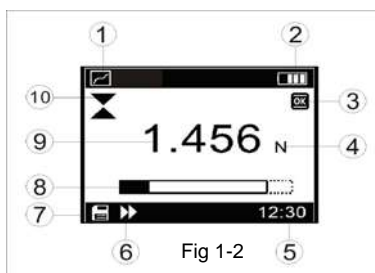





Fig 1-2

① Test mode icon:

 : Track,  : Peak,  : Preset



② Battery icon: Indicating the battery level or charging status,  flashes if the gauge needs to be recharged

③ Preset Mode Test status mark  :

The measured value between the upper limit and lower limit that is OK;

 The measured value between the lower limit and 75% of the lower limit, which means it is below the lower limit

 : The measured value higher than the upper limit

- ④ Test units: Displays selected measuring unit (N, kgf, ozf, and lbf selectable)
- ⑤ System time
- ⑥ Data transmission icon
- ⑦ Data storage icon
- ⑧ Analogue bar
- ⑨ Current measured value
- ⑩ Force direction Indicator - for tension: 
- for compression: 

1.3 Key Functions

 Power: ON/OFF

 Storage / Back

 Zero/Up

 Menu/Enter

 Test Mode/Down

1.4 Specifications

Accuracy	± 0.3% F.S.		
Units	N, kgf, ozf, and lbf.(Selectable)		
Display	160*128 matrix LCD with Backlight		
Overload Capacity	150% of max. (LCD flashes beyond 110% of max.)		
Measurement mode	Track ,Peak and Preset		
Data Sampling Rate	1000 Hz		
Memory	500 data		
Set Point	Programmable high and low limits		
Power	3.6VDC 450mAH Ni-MH rechargeable batteries		
Charger / Adaptor	USB/BM charger, Input:110~240VAC		
Temperature Effects	<0.03% of max per °C		
Dimensions	140x 71.2x 35.5 mm	Weight	0.4 kg (0.9 lb)

2 Operation

2.1 Preparation

Confirm the model

This series force gauge has 5 models which can be selected, each model corresponding to the capacity and resolution, shown in a table on the last page of this manual. Select the appropriate model you need before use.

Choose the adapter

In order to complete the test work convenient, the standard force gauge is equipped with a variety of measuring heads. According to the actual need, please select the appropriate measurement adapter, shown in Fig 2-1:

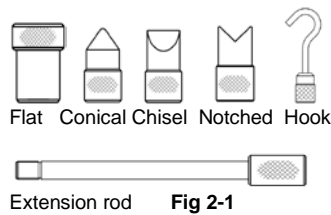





2.2 Testing

After completing the test preparation, testing can be performed.

① How to mount the measuring adapter: Install the adapter in the gauge's measurement shaft. Tighten it by hand, not by any tools.

NOTE: Do not use tools for tighten the adapter; otherwise it will damage the force gauge.

② Select the appropriate units. A variety of measurement units can be chosen.

In the measure interface, press the Menu key  to enter the menu interface, press  or  select Measurement, press  to enter, and then select Unit to enter. Choose the unit you desired here.

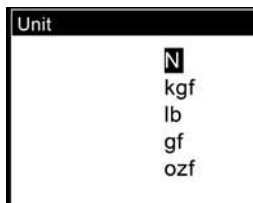



Fig 2-2

③ Select the appropriate Test Mode.

This series has 3 kinds of test modes; select your appropriate test mode for measurement.

Under the measure interface, just press  can change the Test Modes one to another.

You can also set it in Menu, see § 3.2.

Track: The real time measuring mode. Under this mode, press the zero key  and you can remove the tare force.

Peak: In Peak mode, the maximum of force will be measured and displayed. Under this mode, press  and the force gauge will update the display immediately.

Preset: In this mode, you can set the tolerance upper limit and lower limit of measured force value to do a GO/NG measurement. See chapter 3.2.

④ Before measurement, you should zero the tare by pressing .

⑤ The force gauge often is used hand-held. But mounting it on a test stand for use may be more accurate and easier or safer. We just recommend this way of use.

2.3 Save the measured value

Measured results can be stored in the force gauge; you can review or print them later.

During the measurement, press the key  to store a value, and the storage icon  will be displayed.

The data stored is the one displayed currently. So, in Track and Preset mode it is the current force value measured, in Peak mode it is the peak value.

2.4 Browse and print data

All data stored in the memory can be browsed or printed by the mini-printer. See chapter 3.3.1 and 3.3.2 for details.

3 Setup

3.1 Setup menu

This series force gauge has multi-level menu interface. Show as Table 3-1.

Table3-1

Menu	Measurement	Unit
		Test Mode
	Memory	Browse
		Print
		Delete All
	System	Display
		Auto Power
		Backlight
		Key Sound
		Date/Time
		Calibration
		Default
	Language	
	Info	

The setting will be very simple:
Under measure interface: Press Menu key  can enter Menu setup.

Under menu interface: Press  or  can select the item of menu.

Press  will confirm a setup and return.

Press  can cancel some setting and return or just for return.

3.2 Measurement

Measurement item contains the unit of measurement and measurement mode, In Unit, N, kgf, ibf, ozf can be selected, as shown in Fig 3-1.

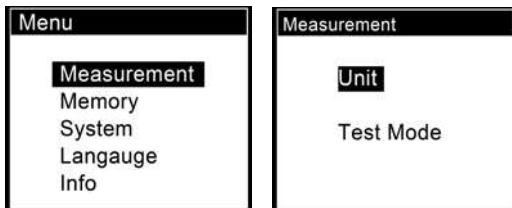

Fig 3-1

In Test Mode Track, Peak, Preset etc. can be chosen (see Fig 3-2, or see §2.2 also) If Preset is selected, the Upper limit and Lower limit can be set.

Press to adjust the number and press to move the next digit.

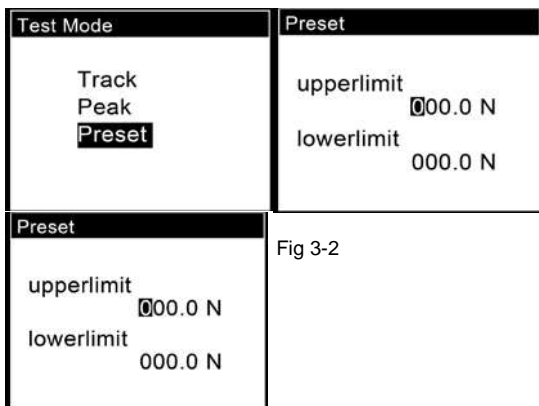

Fig 3-2

Memory item contains three submenus: Browse, Print, Delete all, shown in Fig 3-3. You can browse or print (wireless mini-printer), and delete some (in browse) or all data in memory.

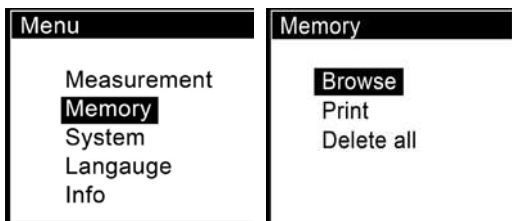

Fig 3-3

3.3.1 Browse

Enter Browse, the data in memory can be reviewed in the order saved.

Press or to move and select.

Maximum number of data is the one obtained recently.

Press and a small window will pop off. Here you can select Delete or Print. See Fig.3-4.

No.	Force	Dir	No.	Force	Dir
013	0.738 N	↕	013	0.738 N	↕
014	1.958 N	↕	014	1.958 N	↕
015	2.136 kgf	↕	015	2.136 kg	↕
016	0.848 lbf	↕	016	0.848 lb	↕
017	1.799 kgf	↕	017	1.799 kgf	↕
018	29.38 ozf	↕	018	29.38 ozf	↕

If you select Delete, a confirm window will appear to ask you confirm.

Or press  to exit.

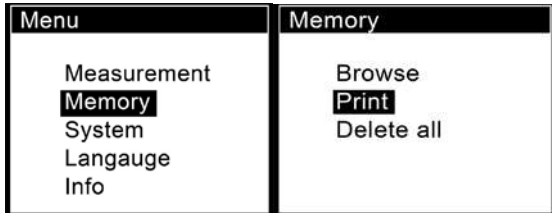

Fig 3-5

3.3.2 Print

You can print the data in memory with mini-printer; see (Fig 3-5)

Enter Print, select Selected or All.

If Selected is chosen, enter the range of number will be needed.

If All is selected, a confirm window will appear to ask you confirm.

See Fig 3-6

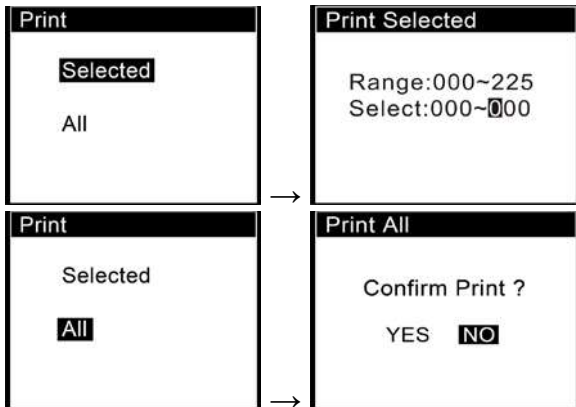

Fig 3-6

3.3.3 Delete All

All data can be deleted at one time to empty the memory (Fig 3-7). A confirm window will appear to ask you confirm.

Deletion of an individual data can be done in Browse, see chapter 3.3.1.

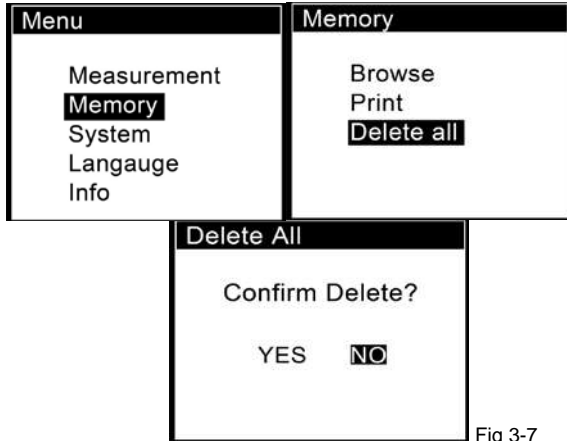
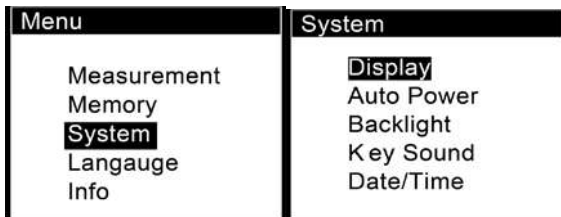

Fig 3-7

3.4 System

Under system settings menu, the display, auto power, backlight, key sound and so on can be set. Fig. 3-8



3.4.1 Display

There are two display modes: Obverse, Reverse, show as Figure 3-7. According to actual needs, select the appropriate display mode, shown in Fig 3-9

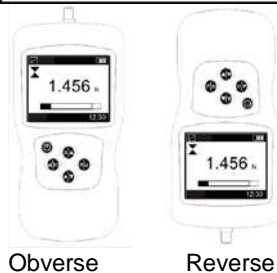
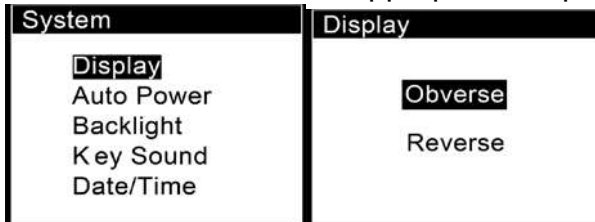

Fig 3-9

3.4.2 Auto Power.

This series force gauge has an automatic power off function.

Turn on the Auto power, if any operation isn't performed within five minutes, it will power off automatically, shown in Fig 3-10:

System	Auto Power off
Display	
Auto Power	On
Backlight	Off
Key Sound	
Date/Time	

3.4.3 Backlight.

The backlight can be set to turn on or off, show in Fig 3-11. Without backlight the consumption of battery will be reduced.

Fig. 3-11:

System	Backlit
Display	
Auto Power	On
Backlight	Off
Key Sound	
Date/Time	

3.4.4 Key Sound



Key sound can be turned on or off by this setting, shown in Fig 3-12.

Fig. 3-12:

System	Key Sound
Display	
Auto Power	On
Backlight	Off
Key Sound	
Date/Time	

3.4.5 Date/time

System date and time can be adjusted under this menu.

Press  to adjust the number and press  to move the next digit.

Shown in Fig 3-13:

System	Date/Time
Display	
Auto Power	12 : 00 :00
Backlight	
Key Sound	2010-10-10
Date/Time	

3.4.6 Calibration

For details, see chapter 5.3.

3.4.7 Default

With this function, the force gauge can be restored back to the factory settings. This function should be performed under the guidance of professionals usually.

3.5 Language

The force gauge can display in multi-language, set the language desired.

See Fig 3-14:

Menu	Language
Measurement	English
Memory	简体中文
System	繁體中文
Language	Deutsch
Info	

3.6 Info

Here you can find out some information about the force gauge, such as model, version and serial number.

See Fig. 3-15:

Menu
Measurement
Memory
System
Language
Info

Fig. 3-15

4 Communication Port

The force gauge has two kinds of ports for recharging and communicating with PC and other equipment.

4.1 USB/Recharge

Using this port, you can connect the gauge to the computer for transform data to PC in accordance with USB2.0.

Or recharge the internal Ni-MH battery by connecting the recharger.

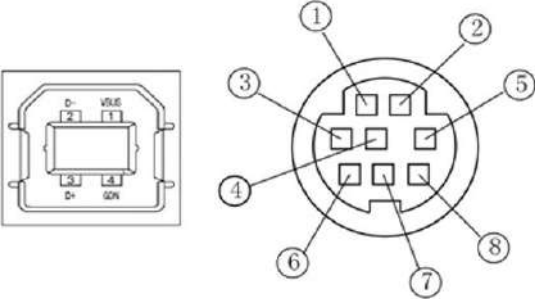

USB/
Recharge

Multifunction
Port

4.2 Multifunction port

The assignment of pins is shown in Table 4-1

Table 4-1 Pin Assignment

Pin#	Description	
1	RS232	Tx
2		Rx
3		Gnd
4	Setpoint Output B	
5		
6	Setpoint Output C (Common)	
7	Setpoint Output A	
8		

4.2.1 RS-232

The RS232 serial port is only used to connect the mini-printer to print the memory data.

RS-232 specifications:

- Hardware Flow Control: **None**
- Data word length: **8 bits**
- Stop bit: **1 bit**
- Parity: **None**
- Baud rate: **38400**

4.2.2 Setpoint Output

Two setpoint outputs are NPN open collector. The internal circuit of setpoint output is shown

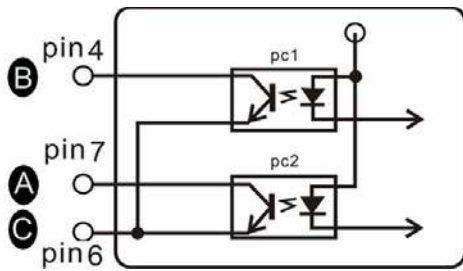

Fig 4-2

Pin7 with Pin6 will be connected when an overload alarm occurs.
 In Preset Mode, Pin7 to Pin6 is connected when the measured value exceeds the upper limit; Pin4 to Pin6 is connected when the measured value is below the lower limit.

! Maximum permissible voltage: pin 7 to 6, pin 4 to 6 must be lower than 35V ; pin 6 to 7, pin 6 to 4 must be lower than 6V .

5 Maintenance and Calibration

5.1 Maintenance

After use, please keep the instrument body clean, do not let oil or other substances infiltrate into the body and the screen, not to damage the instrument.

Please do not forget to remove the load after measurement. Applying a load for a long time may affect the accuracy of the instrument.

Unless there is a special need, please do not switch off the Auto Power, because it can reduce the consumption of the battery and extend batteries life.

5.2 Charging

When the batteries are low, the icon “ ” will be displayed. The batteries should be charged immediately.

Connect the gauge and the charger using the USB cable, and then connect the charger with AC socket to start charging.

It takes about 3~4 hours for completely charging.

5.3 Calibration

Because of the sensor's material performance or the influence of external factors, there may be errors in a certain range after being used a period of times.

The force gauge can be sent to us for a specialized testing and for calibration.

If you have some standard force weights or the other standard load and some test stand, you may calibrate it also on your own, as shown below:

① Mount the force gauge to a test stand or fix it anywhere else

② Remove the tare by using the key .

3 Enter Calibration interface, as shown in Fig 5-1.

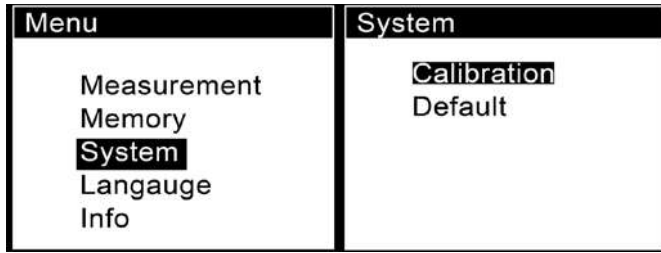

(a)

(b)

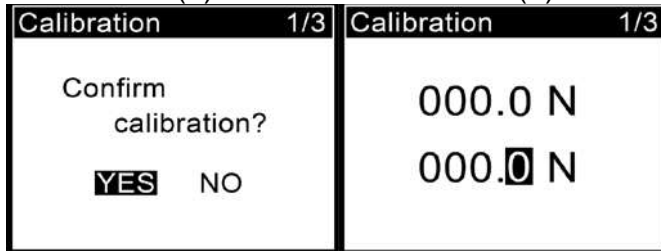

(c)

(d)

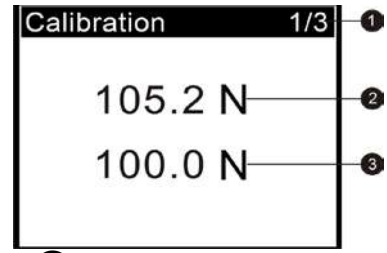



- 1 Calibration times
- 2 Current measuring value
- 3 Standard value input



Fig 5-2

Calibration interface is shown in Fig 5-2

4 Load a standard force. Now the value in standard input area is just equal to the current measured value. Wait a moment for the force stabilization.

5 Press  and  to input the standard force value.

6 Press  to enter the next calibration. Pressing  can interrupt the calibration. When the 3 times calibration had been finished or been interrupted, a confirm window will pop up for asking you "Save and Exit" (YES) or "Save and Exit" (NO), (Fig 5-3a)

Press  or  to select, then press .

If "YES" is selected, "Calibrate complete!" is displayed, see 5-3(b).

5.4 Troubleshooting

If the force gauge in use processes such as errors, please accord to the following way for troubleshooting, see table 5-3. Do not disassemble the gauge by yourself to repair. If you cannot resolve the fault yourself, please contact our company.

5-3(a)

5-3(b)

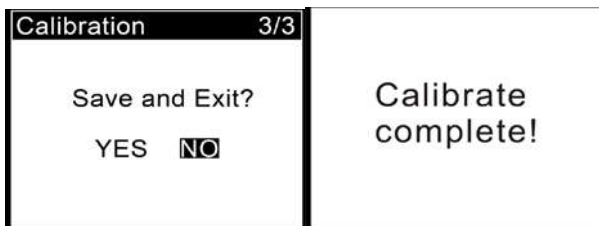
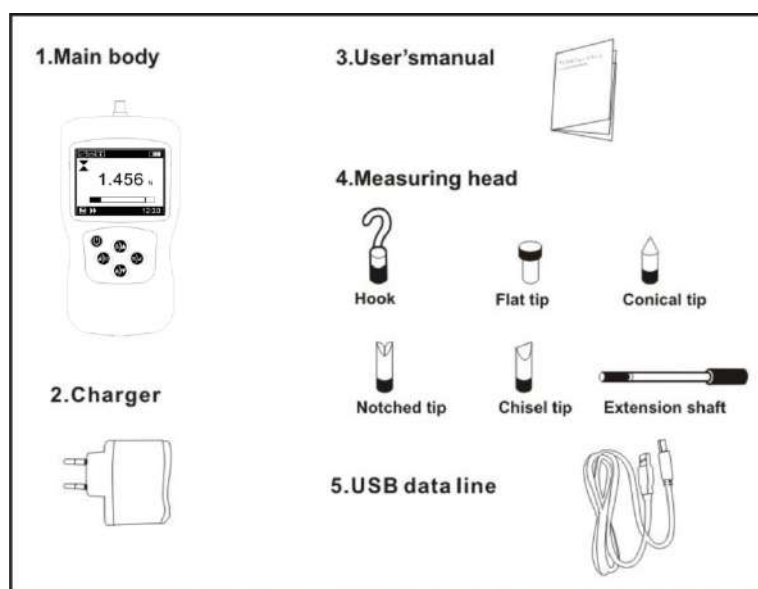

Fig. 5-3

Occuring Error	Possible causes	Treatment measures
Can not turn on	Low battery	Recharging and then boot
Without key sound	Key sound is turn off	Turn on the key sound
No backlight	Backlight is turn off	Turn on the key backlight
Error is too large	The gauge is not calibrated	Calibration force gauge
	The tare has not been removed	Zeroing

Appendix A-1 Packing List



A-2 Dimensions

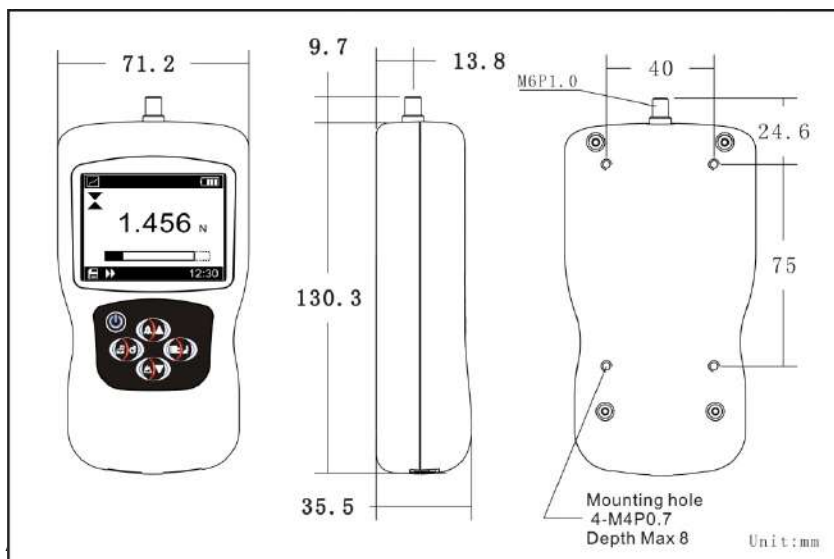

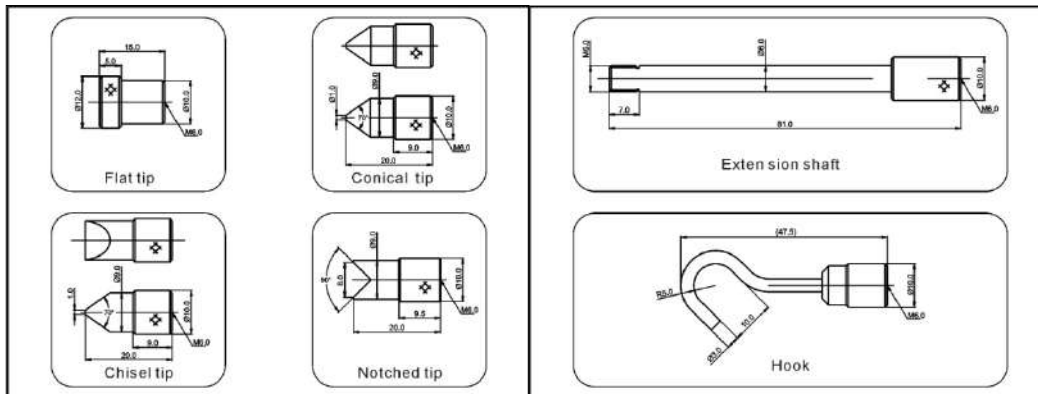

Available FC Models

Model		N	gf	kgf	ibf	ozf
FC 10	Capacity/ Resolution	10/0.01	1000/1	-	2.2/0.002	35.25/0.05
FC 50	Capacity/ Resolution	50/0.05	5000/5	5/0.005	11/0.01	176.2/0.2
FC 100	Capacity/ Resolution	100/0.1	-	10/0.01	22.00/0.02	352.5/0.5
FC 500	Capacity/ Resolution	500/0.5	-	50/0.05	110.0/0.1	1762/2
FC 1K	Capacity/ Resolution	1000/1	-	100/0.1	220.0/0.2	3525/5